

Section IV RUNNING GEAR

TROUBLE SHOOTING

Cont'd

Cause	Remedy
<u>Suspension Noisy and Knocking on the Move</u>	
1. Shock absorbers faulty	1. Replace on repair shock absorbers
2. Loosening of sway eliminator bar bolts	2. Tighten sway eliminator bar bolts and nuts; replace rubber pads, if worn
3. Wear of wishbone silent blocks	3. Replace silent blocks
4. Shock absorbers loosely fastened or rubber bushes of their lugs are worn	4. Tighten bolts and nuts, replace bushes in shock absorber lugs
5. Wear of wishbone ball joints	5. Replace ball joints
6. Excessive clearance in wheel bearings	6. Adjust clearance or replace bearings
7. Heavy unbalance of wheels	7. Have wheels balanced
8. Deformation of wheel discs	8. Replace wheel discs
9. Spring weak or broken	9. Replace spring
10. Wear of rubber bushings of rear suspension radius rods	10. Replace bushings
11. Bumps of rear suspension caused by damage of compression buffers	11. Replace damaged buffers
12. Frequent bumps of rear suspension caused by overloading of rear axle	12. Relieve load on rear axle

Front Wheel Alignment Angles Fail to Be Adjusted

Distortion of lower wishbone shaft or of wishbones	Replace shaft or wishbones
--	----------------------------

Car Pulls Sideways

1. Non-uniform tyre pressure	1. Set correct tyre pressure in all wheels
------------------------------	--

Cause	Remedy
2. Wrong front wheel alignment angles	2. Adjust
3. Wrong clearance in front wheel bearings	3. Adjust
4. Distortion of wishbones	4. Replace distorted wishbones
5. Non-uniform resilience of suspension springs	5. Replace weak spring
6. Incomplete release of wheel brakes	6. Correct defect
7. Considerable difference in wear of tyres	7. Replace worn tyres
8. Heavy unbalance of front wheels	8. Balance front wheels
9. Displacement of rear axle caused by deformation of rear suspension radius rods	9. Straighten out or replace radius rods

Front Wheel Shimmy

1. Tyre pressure other than normal	1. Set correct tyre pressure
2. Excessive clearances in wheel hub bearings	2. Adjust clearances
3. Shock absorbers inoperative	3. Replace or repair shock absorbers
4. Loose nuts of ball joint pins	4. Tighten nuts
5. Wrong front wheel alignment angles	5. Adjust
6. Wear of wishbone shaft silent blocks	6. Replace silent blocks
7. Heavy unbalance of wheels	7. Check and balance wheels
8. Wear of wishbone ball joints	8. Replace joints

Frequent Suspension Bumps

1. Weakening of suspension springs	1. Replace springs by new ones
------------------------------------	--------------------------------

Cause	Remedy
2. Shock absorbers inoperative	2. Replace or repair shock absorbers
3. Distortion of wishbones	3. Replace distorted wishbones

Excessive Clearance in Ball Joints

Friction surfaces of ball joint parts worn with dirt penetrating inside through loose or damaged rubber boot	Replace ball joint and boot
--	-----------------------------

Irregular Wear of Tyre Treads

1. Excessive speed on turns	1. Reduce speed
2. Heavy wear of suspension joints and bushings	2. Repair suspensions
3. Unbalance of wheels (worn spots uniformly arranged over circumference, on extreme tread ribs or, after prolonged driving on unbalanced wheels, on central rib too)	3. Have wheels balanced
4. Non-uniform braking of wheels	4. Adjust brake system
5. Shock absorbers inoperative	5. Replace or repair shock absorbers
6. Wrong camber (wear of tread inner ribs)	6. Adjust wheel camber
7. Underinflated tyres (heavy wear on extreme ends of tread)	7. Inflate tyres as required
8. Overinflated tyres (heavy wear of central tread rib)	8. Inflate tyres as required
9. Insufficient toe-in of front wheels (wear of tread inner ribs)	9. Adjust toe-in
10. Excessive toe-in of front wheels (wear of tread outer ribs)	10. Adjust toe-in

Wheels Wobble

1. Wrong balancing of wheels:	1. Do the following:
(a) non-uniform wear of tyre tread over circumference	(a) balance or replace wheels
(b) shifting of balance weights and tyres during mounting	(b) balance wheels

Cause	Remedy
(c) deformation of wheel rim	(c) true up or replace rim; balance wheels
(d) damaged tyres	(d) replace tyre and balance wheel
2. Excessive clearance in wheel hub bearings	2. Adjust clearance

Fluid Leaks from Shock Absorber

1. Wear or damage of rod gland	1. Replace gland
2. Foreign hard particles get on gland sealing edges	2. Wash shock absorber parts, replace or filter fluid
3. Nicks, notches, scores on rod; complete wear of chromium coating	3. Replace worn or damaged rod and gland
4. Loosening of reservoir nut	4. Tighten up nut
5. Reservoir damaged in sealing ring zone	5. Replace or repair reservoir
6. Reservoir sealing ring shrunk or damaged	6. Replace ring
7. Too much fluid in shock absorber	7. See that shock absorber contains prescribed amount of fluid

Insufficient Resistance of Shock Absorber during Rebound Stroke

1. Poor tightness of rebound or bypass valve	1. Replace or repair faulty valve parts
2. Piston ring broken or stuck in groove	2. Replace ring or eliminate its sticking
3. Lack of fluid caused by leaks	3. Replace faulty parts and fill shock absorber with fluid
4. Piston or cylinder scored	4. Replace damaged parts, replace fluid
5. Wear of hole in guide bushing	5. Replace guide bushing
6. Fluid contaminated with mechanical impurities	6. Wash all parts, replace fluid
7. Weakening of rebound valve spring	7. Replace spring

Insufficient Resistance of Shock Absorber during Compression Stroke

1. Poor tightness of compression valve	1. Replace or repair damaged parts
2. Lack of fluid due to leaks	2. Replace damaged parts, add fluid
3. Wear of guide bushing and rod	3. Replace worn parts by new ones

Cause	Remedy
4. Fluid contaminated with mechanical impurities	4. Wash all parts, replace fluid
5. Wear or damage of compression valve discs	5. Replace damaged parts

Shock Absorber Knocks and Squeaks

1. Wear of rubber bushes in lugs	1. Replace bushes
2. Deformation of dust shield caused by impacts	2. Replace or repair dust shield
3. Lack of fluid caused by leaks	3. Replace damaged parts, add fluid
4. Loosening of reservoir and piston nuts	4. Tighten up nuts
5. Jamming of rod due to deformation of cylinder, reservoir or rod	5. Replace or true up defective parts
6. Loosening of shock absorber fastening nuts	6. Tighten up nuts
7. Breaking of shock absorber parts	7. Replace damaged parts by new ones

Heavy Wear of Tyre Treads

1. High speed motoring	1. Choose correct speed to suit road conditions
------------------------	---

Cause	Remedy
2. Excessively sharp accelerations with slipping of wheels	2. Avoid sharp accelerations
3. Unduly frequent use of brakes	3. Use brakes skillfully
4. Wrong front wheel alignment angles	4. Adjust
5. Excessive clearances in wheel hub bearings	5. Adjust
6. Car overloaded	6. Do not overload car above limits indicated in operating instructions
7. Failure to interchange wheels as recommended in Operating Instructions	7. Interchange wheels as recommended in Operating Instructions

Tyres Squeal on Turns

1. Wrong tyre pressure	1. Set correct tyre pressure
2. Wrong front wheel alignment angles	2. Adjust
3. Distortion of suspension wishbones, cross-member or body front end parts	3. Replace distorted parts, straighten body front end parts

FRONT SUSPENSION

The design of the front suspension is shown in Fig. 4-1.

INSPECTION OF FRONT SUSPENSION PARTS

During each round of maintenance and repairs make sure to examine the protective boots of the suspension ball joints, paying particular attention to absence of mechanical damage. Scrutinize the suspension parts carefully for cracks, signs of rubbing against road obstacles or car body, distortions of the lower wishbone shafts, crossmember or suspension wishbones and body front elements and check the condition of the ball joints and silent blocks.

Distortion of the lower and upper wishbone shaft is checked visually.

Distortion of the front suspension cross-member is determined by measuring the distance between the outer surfaces of the crossmember brackets in the zone of the upper wishbone shaft fastening bolts. This distance should be 736 ± 1.5 mm.

If the crossmember is distorted to such an extent that the wheel alignment angles cannot be

adjusted with washers, though the other elements of the suspension are in order, replace the cross-member.

The silent blocks should be examined as follows:

- make sure there is no deformation of the suspension wishbones, lower wishbone shaft, and suspension crossmember; then jack up the front wheels of the car;

- measure radial displacement A (Fig. 4-2) of outer bushing 2 relative to inner bushing 6 and distance B between thrust washer 5 and the outer face of outer bushing 2.

The silent blocks of the upper and lower wishbones must be replaced in the following cases:

- when rubber is fractured or bulged on one side;

- if rubber is undercut and worn on silent block faces;

- if radial displacement A of the outer bushing relative to the inner one exceeds 2.5 mm;

- if distance B goes out of 3 - 7.5 mm limits.

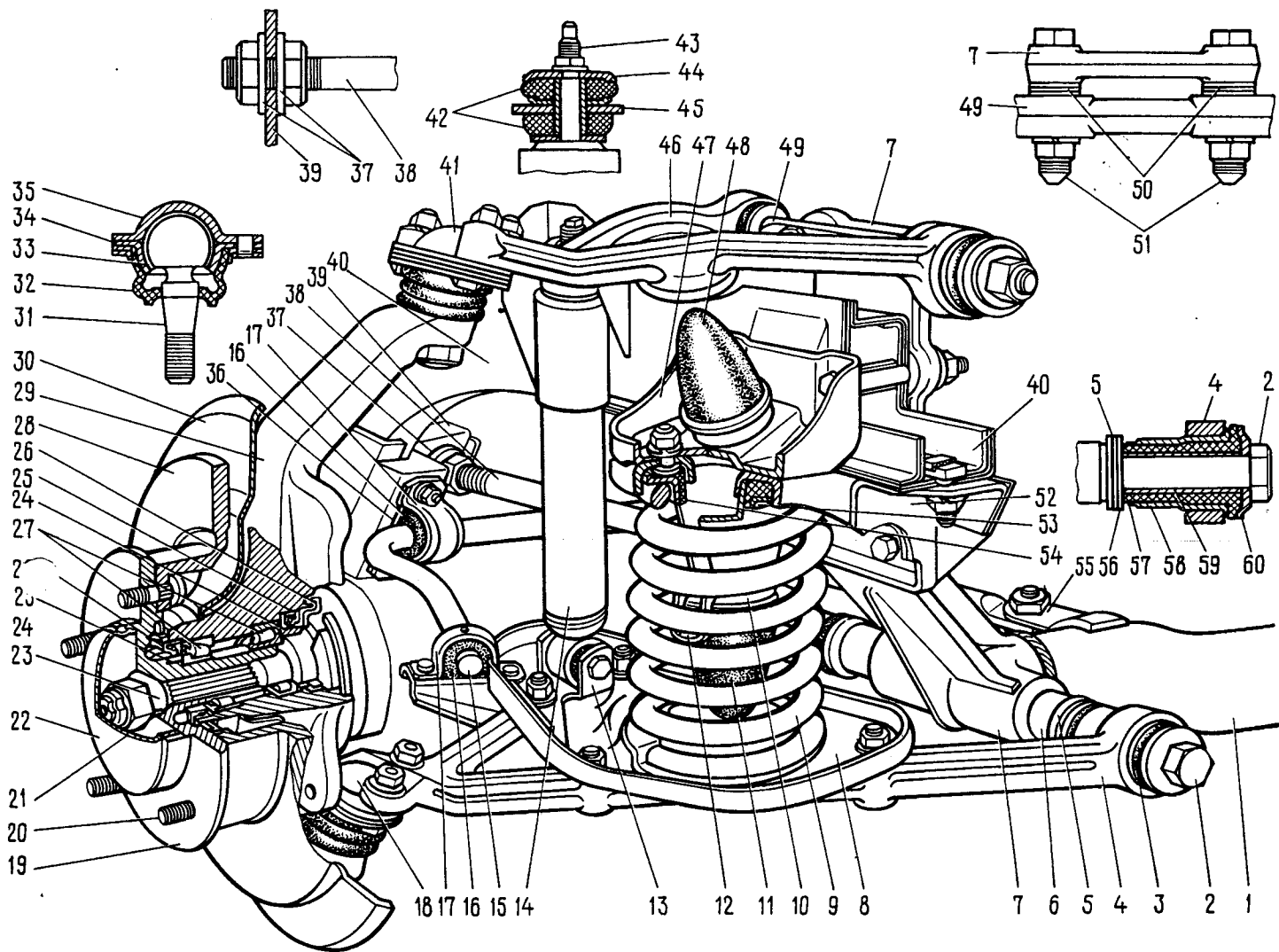

Fig. 4-1. Front Suspension:

1 - front suspension crossmember; 2 - lower wishbone shaft; 3 - lower wishbone silent block; 4 - lower wishbone; 5 - lower wishbone adjusting washers; 6 - lower wishbone shaft bushing; 7 - crossmember bracket; 8 - suspension spring lower seat; 9 - suspension spring; 10 - compression buffer support post; 11 - compression buffer; 12 - compression stroke stop; 13 - shock absorber lower bracket; 14 - shock absorber; 15 - sway eliminator bar; 16 - rubber pad; 17 - sway eliminator bar holder; 18 - lower ball joint; 19 - wheel hub; 20 - brake disc and wheel bolt; 21 - tapered bushing; 22 - cap; 23 - outer constant velocity universal joint housing extension; 24 - gland bushing; 25 - gland; 26 - mud deflecting ring; 27 - wheel hub bearings; 28 - brake disc; 29 - steering knuckle; 30 - front brake

guard housing; 31 - ball joint pin; 32 - boot; 33 - bearing; 34 - ball pin seat holder; 35 - ball pin bearing housing; 36 - sway eliminator bar fastening plate; 37 - washers; 38 - tension member; 39 - tension member bracket; 40 - body sidemember; 41 - upper ball joint; 42 - shock absorber rod pad; 43 - shock absorber rod; 44 - washer; 45 - shock absorber bracket; 46 - suspension upper wishbone; 47 - rebound buffer bracket; 48 - rebound buffer; 49 - suspension upper wishbone shaft; 50 - adjusting washers; 51 - upper wishbone shaft bolts; 52 - suspension spring upper support; 53 - suspension spring upper seat; 54 - spring insulating gasket; 55 - tension member-to-crossmember bracket; 56 - thrust washer; 57 - rubber bushing; 58 - outer bushing; 59 - inner bushing; 60 - thrust bushing

If distance B goes beyond the above-specified limits, check silent block press-fitting in the wishbone socket.

The clearance in the upper ball joints should be checked as follows:

- put the car on a level horizontal hard-surface floor;
- jack up the R.H. (L.H.) front side of the car and take off the wheel;
- put a 230 mm-high wooden block under the

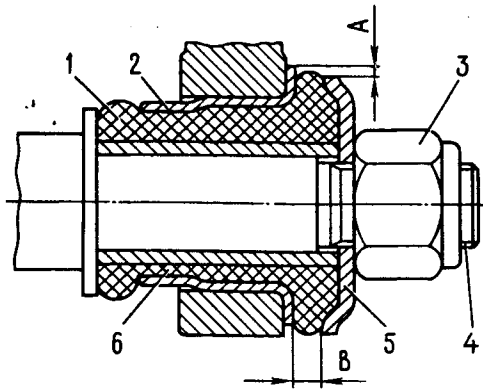

Fig. 4-2. Examining Front Suspension Wishbone Silent Block:

- 1 - rubber bushing; 2 - outer bushing; 3 - shaft nut; 4 - wishbone shaft; 5 - joint thrust washer; 6 - inner bushing

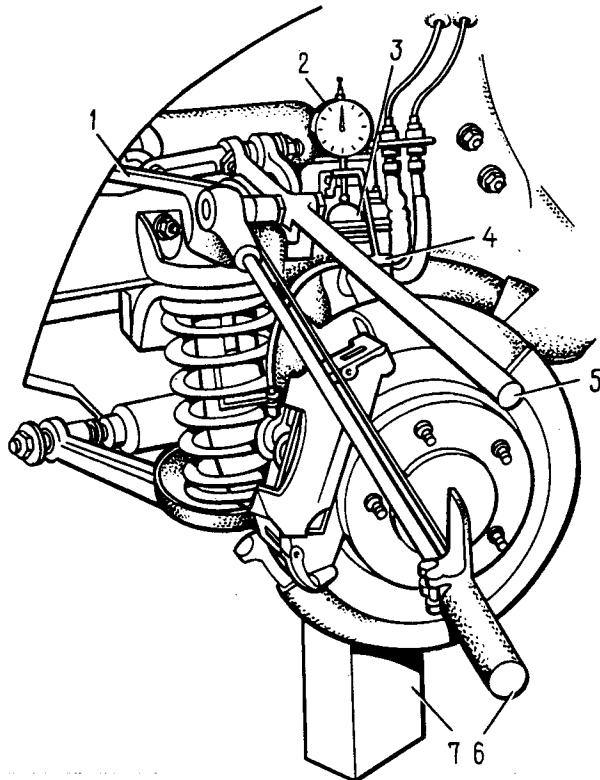

Fig. 4-3. On-Car Checks of Clearance in Suspension Upper Ball Joints:

- 1 - upper wishbone; 2 - indicator; 3 - upper ball joint housing; 4 - indicator bracket; 5 - lever; 6 - torque-indicating wrench; 7 - block

lower wishbone nearer to the ball pin and ease down the car on the block;

- make sure that resin does not ooze out of the hole in the upper ball pin housing; if necessary, remove it with a file to prevent measurement errors;

- secure indicator bracket 4 (Fig. 4-3) on the upper end of the steering knuckle;

- set indicator 2 in the centre of the sphere of upper ball joint housing 3 with a small preliminary tension and then align the zero division of the indicator scale with the pointer;
- secure 0.7 m long forked lever 5 on the upper wishbone of the front suspension;
- build up a load of 196 N.m (20 kgf.m) in the vertical direction with torque-indicating wrench 6 (294 N on the end of the forked lever) first for pushing the ball pin into, then for pulling it out of, the joint housing;
- register the respective maximum deflections of the indicator pointer;
- calculate the values of the clearance in the upper ball joint by summing up the deviations from the zero division;
- the summary readings of the indicator should not exceed 0.8 mm.

FRONT WHEEL ALIGNMENT

The front wheel alignment angles should be checked and adjusted on special stands as instructed in their Operating Instructions.

Caution

The checks of the wheel alignment angles are mandatory after replacement or repairs of the suspension parts which may disturb the angle settings.

Check and adjust the wheel alignment angles on a car under a static load of 3140 N (320 kgf) which corresponds to the weight of four men and a 40-kg load in the trunk.

The alignment angles should be as follows:

- camber $0^{\circ}30' \pm 20'$;
- caster $3^{\circ}30' \pm 30'$;
- toe-in 3 ± 1 mm.

Prior to adjustment check the following:

- tyre pressure;
- axial clearance in front wheel hub bearings;
- condition of shock absorbers (absence of rod jamming);

- radial and axial wobble of tyres;
- clearance in suspension ball joints;
- steering wheel play.

Eliminate any discovered defects and make necessary adjustments.

After installing the car on a stand, directly before checking the alignment angles, "pump" the car suspension, by pushing down first the rear then the front bumper two or three times with a force of 392 - 490 N (40 - 50 kgf).

The sequence of adjustments should be as follows:

1. Caster
2. Camber
3. Toe-in.

Caster. If the measurements show that the caster angle comes out of the above-specified limits, change the number of adjusting washers 50 (Fig. 4-1) installed between the upper wishbone shaft and the crossmember bracket (see Table 4-1).

To adjust the caster angle:

- unscrew the nuts holding the upper wishbone shaft and transfer the washers from one bolt to the other until the angle is as prescribed. The caster angle increases when the washers are transferred from the rear bolt to the front one and vice versa;
- turn on the nuts with a torque-indicating wrench and check for correct caster angle.

Camber angle. If the camber angle is other than normal, adjust it by changing the number of washers 50 (Fig. 4-1) installed between the upper wishbone shaft and the crossmember bracket.

To decrease or increase the camber angle, remove or add the identical number of washers on both bolts, respectively.

Table 4-1

Adjustments of Camber and Caster by Shims

Number of washers added or removed		Camber	Caster
front bolt	rear bolt		
+1	+1	+(8'42")	0
-1	-1	-(8'42")	0
+1	0	-(7'30")	+(20'24")
-1	0	+(7'30")	-(20'24")
0	+1	+(15'18")	-(25'18")
0	-1	-(15'18")	+(25'18")
-1	+1	+(27'30")	-(43'18")
+1	-1	-(21'36")	+(40')

Note. These data refer to washers 0.75 mm thick. The sign "plus" or "minus" means that a washer must be added or removed, respectively.

Toe-in of front wheels. If the toe-in is other than normal, loosen the clamps of the side rods and turn both sleeves with wrench 67.7813.9504 through the same angle in opposite directions; in this manner the sleeves are turned on or off, thus changing the length of the side steering rods.

On completion of adjustments install the clamps with their slots facing backwards, with maximum tolerable tilting by 60° to the horizontal plane. With the nuts tightened the edges of the clamp slots should not meet.

Having adjusted the toe-in check to see that the wheels and the parts of the steering linkage do not rub against the adjacent parts of the suspension and body. For this purpose turn the wheels all the way back and forth until the pitman arm comes to bear against the bolts of the steering gear case.

CHECKS AND ADJUSTMENT OF CLEARANCES IN FRONT WHEEL HUB BEARINGS

To check the clearance remove the cap, loosen the wheel nuts, then jack up the front end of the car, put it on a support and remove the front wheel.

Remove the front brake caliper with brake shoes. See that the caliper does not hang down from the H.P. hoses.

Fasten gauge 67.7834.9507 with an indicator (Fig. 4-4) on the steering knuckle so that the indicator rod bears against the wheel hub as near to the adjusting nut as possible. Turning the hub back and forth, move it with lever 67.7820.9521 along the steering knuckle axis (forward and back). Measure the displacement (clearance) with the indicator.

If the clearance is larger than 0.15 mm, adjust it as follows:

- turn off the adjusting nut from the outer joint housing extension;
- install a new nut or a used nut from another car and screw it on with a torque of 19.6 N.m (2 kgf.m), at the same time rotating the hub back and forth two or three times to allow the bearing rollers to seek their proper places;
- loosen the adjusting nut and tighten it up again with a torque of 6.86 N.m (0.7 kgf.m);

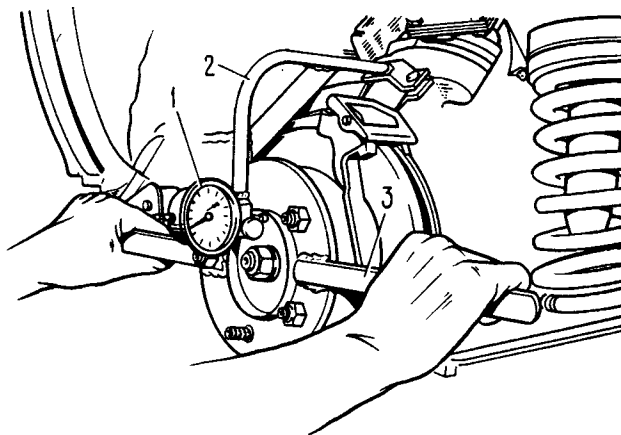

Fig. 4-4. Checking Axial Clearance in Front Wheel Hub Bearings:

1 - indicator; 2 - gauge 67.7834.9507; 3 - lever 67.7820.9521

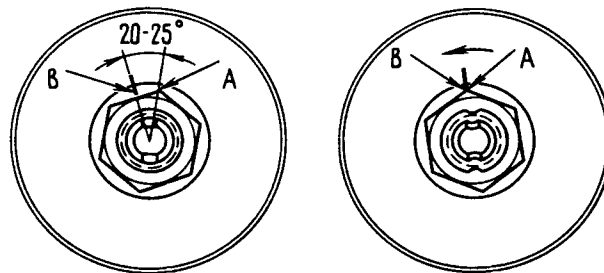

Fig. 4-5. Tightening and Adjusting Front Wheel Hub Bearings:

A - nut edge; B - mark on washer

- make mark B on the washer (Fig. 4-5) then back off the nut through 20 - 25° until the first edge A gets in line with the mark;

- lock the nut in this position, forcing the metal on the nut neck into the slots on the end of the outer joint holder extension.

After adjustments the clearance in the bearing should range from 0.01 to 0.07 mm.

REPLACEMENT OF GREASE IN FRONT WHEEL HUB BEARINGS

Do the following on both sides of the car:

- jack up the front end of the car and remove the wheel;

- unbend the edges of the brake front guard, unscrew the bolts of the brake shoe guide and take the brake caliper off the brake disc, shifting it aside. Do not disconnect the brake hoses so as to prevent ingress of air into the hydraulic system and see that the caliper does not hang on the hoses;

- using remover tool 67.7823.9514, remove the cap from the wheel hub, unscrew the adjusting nut and remove bushing 2I (Fig. 4-1);

- taking care not to damage gland 25, remove hub 19 complete with the brake disc;

- put a support under lower wishbone 4 and ease down the front end of the car a little so as to compress spring 9;

- disconnect lower ball joint 18 from the wishbone;

- detach shock absorber 74 from lower wishbone 4 and the side steering rod from the arm of steering knuckle 29;

- shift the front wheel drive shaft all the way towards the front axle;

- turning steering knuckle 29 relative to upper ball joint 41 remove the knuckle from universal joint housing extension 23;

- using handle 67.7853.9535 with washer 67.7853.9540, drive the inner races of bearings 27 from the steering knuckle space complete with dismantling rings and glands 25. Drive out the outer races of the bearings using washer 67.7853.9534 and drive them in with the aid of mandrel 67.7853.9536. Mark the bearing races so as to install them back where they belong;

- remove the old lubricant and wash with kerosene the inner space of the steering knuckle, outer and inner spaces of the hub, constant velocity universal joint housing extension and bearings;

- pack 40 g of fresh grease ЛитоЛ-24 into the bearing cages, apply it in a uniform layer in the steering knuckle spaces between the bearings and lubricate the splines of the joint housing extension;

- install the bearing inner races, the dismantling rings and press-fit the glands;

- put the steering knuckle on the extension of the universal joint housing and connect the ball joint to the lower wishbone;

- secure the shock absorber and connect the side steering rod to the knuckle arm;

- install the hub complete with the brake disc on the joint housing extension and install tapered bushing 21;

- screw on a new adjusting nut and adjust the clearances in the wheel hub bearings;

- install the wheel hub cap with mandrel 67.7853.9528;

- put in place the brake caliper and the wheel.

Note. In all cases when the nut has been removed from the extension of the outer joint housing, replace it by a new one or use a nut removed from another car.

BALANCING OF WHEELS

The wheels should be balanced on special stands in accordance with the stand Operating Instructions. The unbalance can be eliminated by the use of balance weights held on the wheel rim by special springs.

REMOVAL AND INSTALLATION OF FRONT SUSPENSION

Install the car on a lift or an inspection pit, apply the parking brake, open the hood and remove the spare wheel.

Put chocks under the rear wheels and remove the front ones.

Using remover tool 67.7824.9516 (Fig. 5-10), drive the pins out of the steering knuckle arms and shift aside the steering rods.

Disconnect sway eliminator bar 6 (Fig. 4-6) from the suspension lower wishbones.

Disconnect tension members 5 from the body brackets and crossmember.

Detach the shock absorbers from the suspension lower wishbones.

Remove the engine sump protective shield and the splashguard.

On each side of the car remove the front brake caliper without disconnecting the brake hoses and suspend it so that it does not hang on the hoses.

Compress the suspension spring to relieve completely the lower wishbone.

Disconnect the ball joint from the lower wishbone and take off the spring, relieving it gently; repeat the same operations on the other suspension unit.

Disconnect upper wishbone shaft 49 (Fig. 4-1) from suspension crossmember bracket 7 and remove upper wishbone 46 complete with the steering knuckle, wheel hub, front brake and outer joint housing.



Fig. 4-6. Front Suspension Mounted on Car. Rear View:

1 - lower wishbone; 2 - crossmember; 3 - tension

member bracket; 4 - sway eliminator bar-to-body bracket; 5 - tension member; 6 - sway eliminator bar

Note. When removing the upper wishbone shaft, take a note of the number and location of the washers between the upper wishbone shaft and the crossmember and of the adjusting plates between the crossmember and the body sidemember so as to return the washers and plates to their previous places during reassembly.

Disconnect the engine mount rubber pads from the crossmember brackets.

Put a hydraulic jack with a fixing device under the suspension crossmember and, supporting the engine with cross beam 67.7820.9514 or a hoist, detach the suspension crossmember from the body sidemembers, and brackets 47 of the rebound buffers.

Take off crossmember 1 complete with lower wishbones 4.

Install the suspension units and parts in the reverse order of removal operations. The suspension springs should belong to the same class (class A - unmarked, class B - black marks on the coil outer surface). It is permissible to install class A springs in the front suspension if the rear suspension is provided with class B springs.

Having assembled and installed the suspension check the wheel alignment angles and the toe-in.

DISASSEMBLY AND ASSEMBLY OF FRONT SUSPENSION UNITS

Disassembly. If the suspension repairs call for a complete stripping of its units, this should

better be begun directly on the car, after removing the sump protective shield and the splashguard.

Proceed as follows:

- unscrew the nut of the pin of upper ball joint 41 (Fig. 4-1) and free the hoses from the clips;

- unbend the tongues of the guard, turn out the bolts of the caliper guide and shift it aside complete with the caliper;

Caution

To protect the hoses against damage, see that the caliper does not hang on them.

- using remover tool 67.7823.9514, take off the hub cap and unscrew the nut of the wheel hub bearings;

- remove the front wheel hub complete with the brake disc using remover tool 67.7823.9516;

- remove the guard of the front brake;
- take down the front suspension shock absorber;

- compress the suspension spring to relieve completely the lower wishbone, easing the wishbone down on a support;

- disconnect the ball joint housings from the suspension lower and upper wishbones and remove the steering knuckle;

- relieve gently and remove the suspension spring;

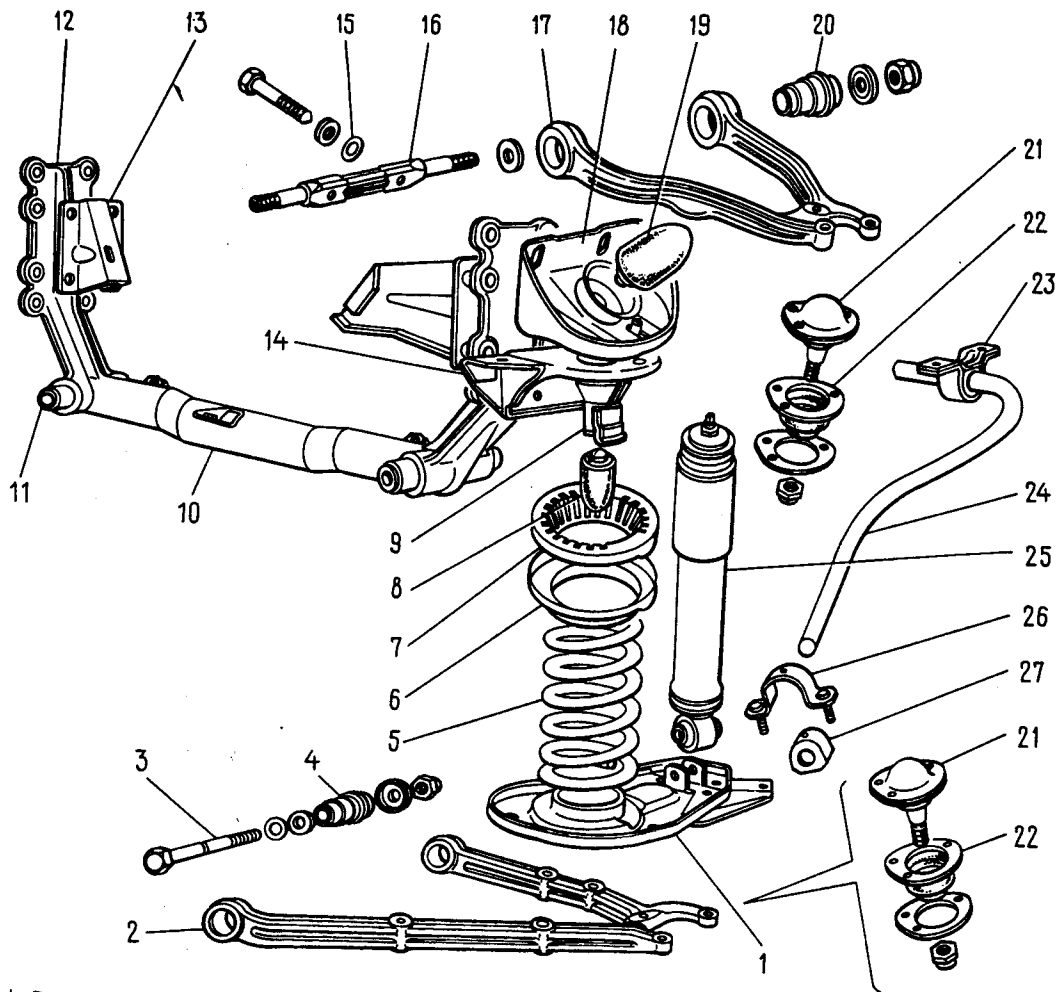

Fig. 4-7. Front Suspension Parts:

1 - suspension spring lower seat; 2 - lower wishbone; 3 - lower wishbone shaft; 4 - lower wishbone silent block; 5 - spring; 6 - upper seat; 7 - spring insulating gasket; 8 - compression stroke buffer; 9 - compression stroke stop; 10 - suspension crossmember; 11 - crossmember bracket bushing; 12 - crossmember bracket; 13 - engine mount

bracket; 14 - spring upper support; 15 - adjusting washer; 16 - upper wishbone shaft; 17 - upper wishbone; 18 - rebound stroke buffer bracket; 19 - rebound stroke buffer; 20 - upper wishbone silent block; 21 - ball joint; 22 - ball pin boot; 23 - bar-to-body bracket; 24 - sway eliminator bar; 25 - shock absorber; 26 - pad holder; 27 - pad

- using remover tool 67.7823.9515, knock out the shaft and disconnect the lower wishbone from the crossmember;

- disconnect the upper wishbone shaft from the crossmember and take off the shaft complete with the wishbone;

Note. Before removing the shafts of the upper and lower wishbones, count the number of washers on each end of the lower wishbone shaft and on the bolts of the upper wishbone shaft so as to put them in their own places during reassembly.

- remove the crossmember and the rebound buffer bracket as described above;

- using remover tool 67.7824.9516, drive the ball joint pins out of the steering knuckle holes.

The parts of the front suspension are shown in Fig. 4-7.

Assembly of the front suspension units is carried out in the reverse order of disassembly operations. When assembling the wheel hub, put a layer of ЛитоЛ-24 grease into the bearing cages and apply a uniform layer of this grease into the steering knuckle space between the bearings, 40 g per knuckle.

When installing the crossmember tension members, screw on the inner nut until the clearance between the washer and bracket 3 (Fig. 4-6) is taken up; turn on the outer nut with a torque specified in the Appendix.

To avoid wrong distribution of forces in the silent blocks, turn on the wishbone shaft nuts under a static load of the car equal to 3140 N (320 kgf). Then check and adjust the wheel alignment angles and the toe-in.

INSPECTION

Ball joints. Make sure that the ball joint boots are intact; they should be free of such defects as fractures, cracks, separation of rubber from metal and leakage of lubricant.

Examine the working surfaces of the ball joints for wear, turning the ball pin by hand. Play or jamming of the pin are impermissible.

The condition of the ball joint can be assessed more accurately by the amount of radial and axial clearances measured with gauge 02.8701.9502. For this purpose install ball joint 1 (Fig. 4-8A) into the gauge socket and clamp it with a screw. Place indicator 2 into the gauge bracket with the indicator rod bearing against the side surface of the joint housing, and the indicator pointer at the zero division.

Insert torque-indicating wrench 3 into the upper socket of the gauge and, applying a torque of 195 N.m (20 kgf.m) in both directions, read the summary radial clearance in the ball joint from indicator 2. If the clearance is larger than 0.7 mm, replace the ball joint by a new one.

Measure the axial clearance in the ball joint in the same manner, first changing its fastening

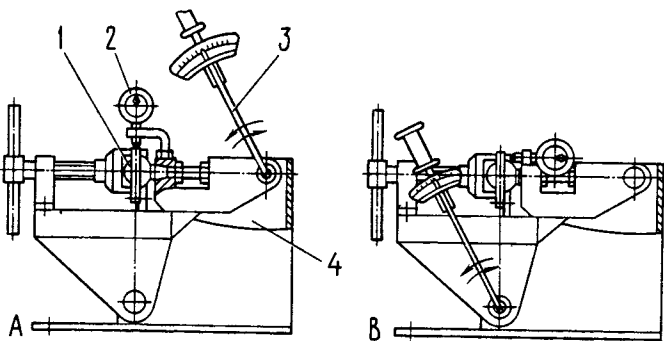

Fig. 4-8. Checking Ball Joint on Gauge 02.8701.9502:

1 - ball joint; 2 - indicator; 3 - torque-indicating wrench; 4 - gauge 02.8701.9502; A - checking radial clearance; B - checking axial clearance

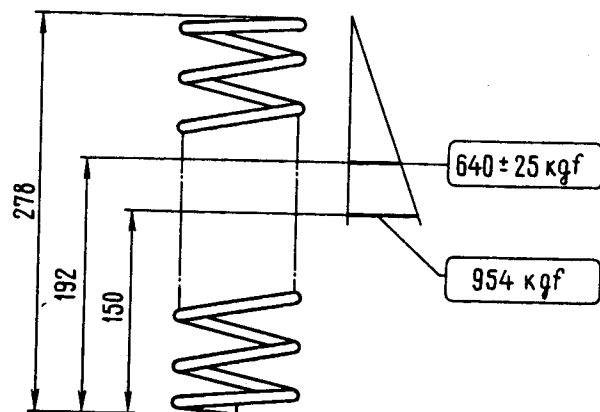

Fig. 4-9. Main Data for Checking Front Suspension Spring

in the gauge as shown in Fig. 4-8B. The maximum permissible axial clearance in the joint is not over 0.7 mm.

Suspension spring. Examine the springs thoroughly and replace them by new ones if the nature of deformations may render them unfit for further service.

Compress the spring three times until its coils close and check its resilience by the reference points (Fig. 4-9).

Examine the insulating gaskets and replace them, if necessary.

Sway eliminator, wishbones, steering knuckle. Check the sway eliminator bar for distortion and see that its ends are in one plane. Straighten out the bar if distortion is slight or replace it, if heavy.

Make a close examination of the wishbones, crossmember and steering knuckles to see that they are neither distorted nor cracked.

Replace any cracked and distorted parts.

Front suspension crossmember. Check the geometrical parameters of the crossmember with gauging mandrel 67.8732.9501. When the crossmember is seriously distorted and the front wheel alignment angles cannot be adjusted by washers though all the other suspension elements are intact, replace the crossmember.

Silent blocks. The necessity for replacing the silent blocks is determined in "Inspection of Front Suspension Parts" above.

REPLACEMENT OF SILENT BLOCKS

Upper wishbone. Install fixture 67.7823.9527 on the shaft between the wishbone lugs and place the wishbone on mandrel A.47045 (Fig. 4-10). Apply the press punch to wishbone shaft 1 until silent block 3 is pressed out of the hole. To press out the other silent block turn the wishbone over and repeat the same operation.

The silent blocks of the upper wishbones are press-fitted with the aid of fixture 67.7853.9519 (Fig. 4-11) clamped in a vice. Place the wishbone with shaft 1 on fixture 2, put the silent block on the shaft and drive it into the wishbone socket with installation tool 3 (A.74177/1). Then repeat the same operations for driving in the other silent block on the other side of the wishbone.

Lower wishbone. The silent block can be driven in and out either on a press with the aid of fixture 67.7823.9526 or using fixture 67.7823.9517 (Fig. 4-12) installed on the wishbone, with the head of the fixture screw directed inward. Press out the silent block by turning in the screw.

To press-fit, insert the silent block into the wishbone socket and install fixture 67.7823.9517 (Fig. 4-13) together with cap 3.

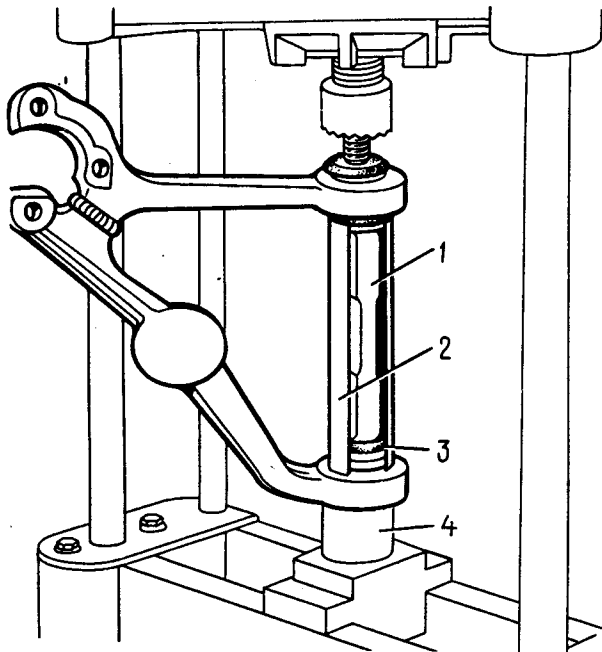

Fig. 4-10. Pressing Out Upper Wishbone Silent Blocks:

1 - wishbone shaft; 2 - fixture 67.7823.9527;
3 - silent block; 4 - mandrel A.47045

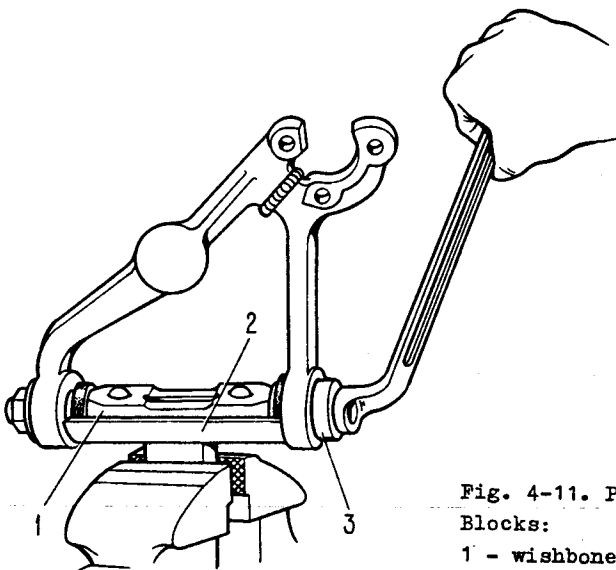

Fig. 4-11. Press-Fitting Upper Wishbone Silent Blocks:

1 - wishbone shaft; 2 - fixture 67.7853.9519;
3 - installation tool A.74177/1

Turning in the fixture screw, press-fit the silent block into the wishbone socket.

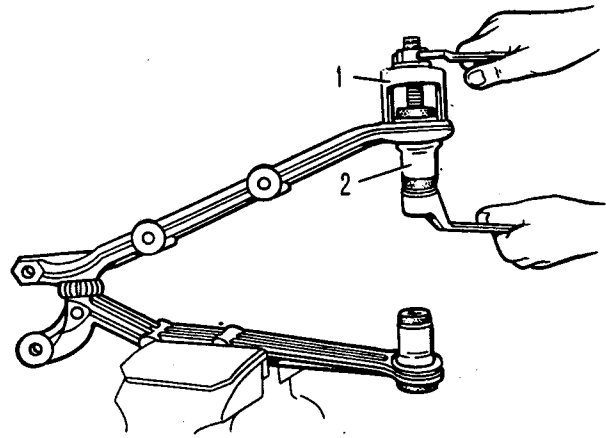

Fig. 4-12. Pressing Out Lower Wishbone Silent Blocks:

1 - fixture 67.7823.9517; 2 - silent block

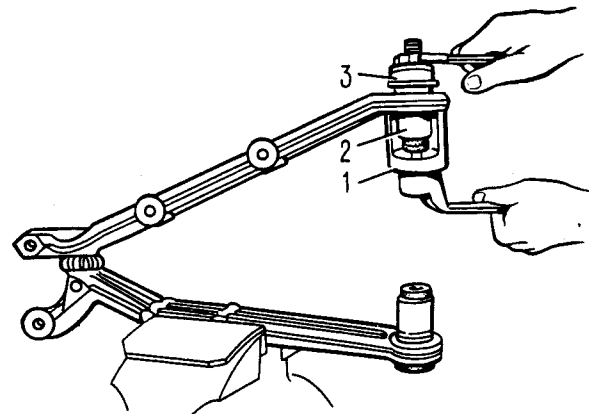

Fig. 4-13. Press-Fitting Lower Wishbone Silent Blocks:

1 - fixture; 2 - silent block; 3 - cap

REAR SUSPENSION

The design of the rear suspension is shown in Fig. 4-14.

REMOVAL AND INSTALLATION

Removal. Jack up the rear end of the car and put it on supports. Remove the rear wheels.

Disconnect the propeller shaft from the final drive pinion flange.

Disconnect the hydraulic brake hose from the steel pipe mounted on the axle and take measures to prevent fluid leaks from the brake system.

Disconnect the brackets of the parking brake rear cable from the car body, take off the front cable return spring and, unscrewing the locknut and the adjusting nut, free the rear cable. Disconnect rod 13 (Fig. 4-14) of the rear brake pres-

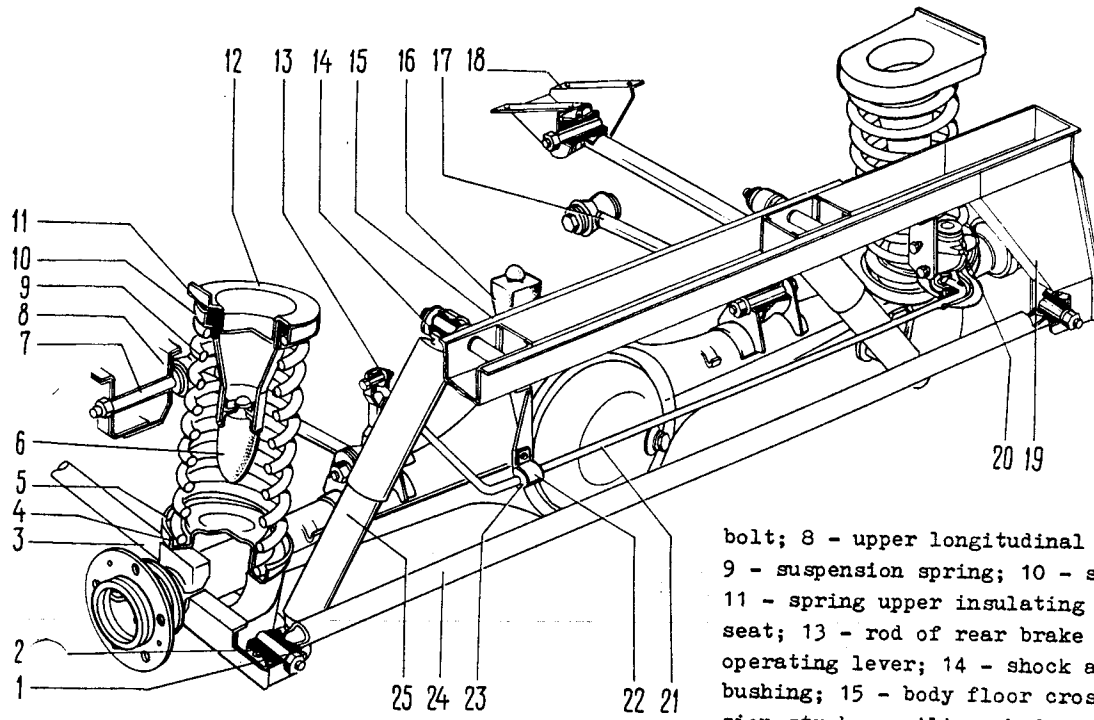

bolt; 8 - upper longitudinal radius rod bracket; 9 - suspension spring; 10 - spring upper seat; 11 - spring upper insulating gasket; 12 - spring seat; 13 - rod of rear brake pressure regulator operating lever; 14 - shock absorber lug rubber bushing; 15 - body floor crossmember; 16 - compression stroke auxiliary buffer; 17 - upper longitudinal radius rod; 18 - lower longitudinal radius rod bracket; 19 - transverse radius rod-to-car body bracket; 20 - brake pressure regulator; 21 - pressure regulator operating lever; 22 - lever supporting bushing holder; 23 - lever supporting bushing; 24 - transverse radius rod; 25 - shock absorber

Fig. 4-14. Rear Suspension:

1 - spacer bushing; 2 - rubber bushing; 3 - lower longitudinal radius rod; 4 - spring lower insulating gasket; 5 - spring lower seat; 6 - compression stroke buffer; 7 - upper longitudinal radius rod

Fig. 4-15. Rear Suspension Parts:

1 - lower longitudinal radius rod; 2 - rubber bushing; 3 - bracket; 4 - spacer bushing; 5 - upper longitudinal radius rod; 6 - compression stroke auxiliary buffer; 7 - spring; 8 - spring upper seat; 9 - compression stroke buffer; 10 - spring upper insulating gasket; 11 - shock absorber; 12 - spring lower insulating gasket; 13 - transverse radius rod

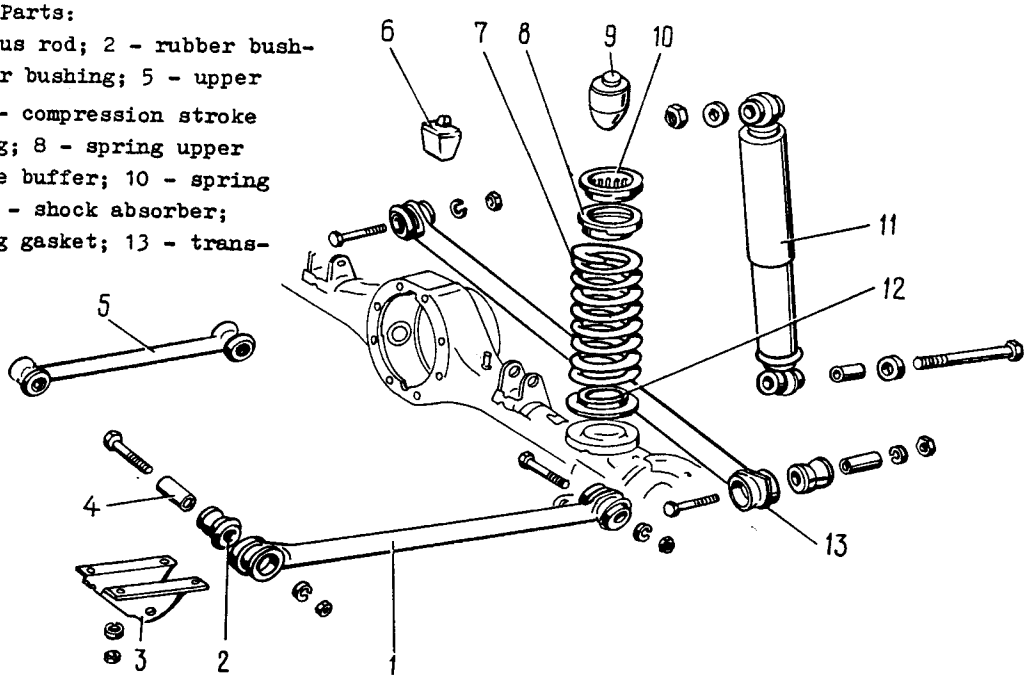

sure regulator from the bracket on the axle beam. Disconnect the upper ends of shock absorbers 25.

Put a hydraulic jack under the rear axle beam. Disconnect longitudinal (3, 17) and transverse (24) radius rods from the brackets on the body, then lower the jack and remove the rear axle.

Proceed with disassembling the suspension:
 - remove the shock absorbers from the brackets on the rear axle beam;
 - disconnect the longitudinal and transverse radius rods from the brackets on the rear axle beam.

The parts of the rear suspension are shown in Fig. 4-15.

Installation. To install the rear suspension reverse the removal operations.

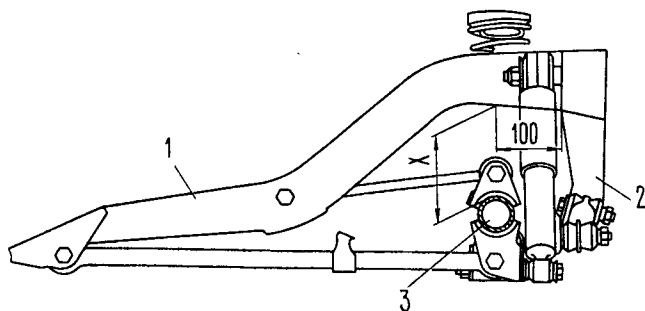

Fig. 4-16. Rear Suspension Installation Diagram:
1 - body sidemember; 2 - transverse radius rod bracket; 3 - rear axle beam; X = 152 mm

The springs of the rear suspension should belong to the same class as those used in the front suspension. In exceptional cases, when class A (unmarked) springs are used in the front suspension and such springs are not available for the rear suspension, class B springs (marked black) may be used. If the front suspension has class B springs, the rear suspension must have only class B springs too.

To avoid damaging and overtightening the flexible bushings of the radius rod joints and shock absorbers:

- load the rear end of the car so that distance "X" from the axle beam to the body sidemember measured at a point located 100 mm from the transverse radius rod bracket (Fig. 4-16) is 152 mm;

- using a torque-indicating wrench tighten the nuts of the bolts of the longitudinal and transverse radius rods, also the nuts of the pins which fasten the the shock absorbers to the axle beam and the car body.

Inspection

Before inspection take care to wash all the parts thoroughly.

SHOCK ABSORBERS

The design of the front and rear suspension shock absorbers made at the VAZ autoplant is shown in Fig. 4-18.

STAND CHECKS

To access the serviceability of a shock absorber check its performance curve on a dynamometer test stand.

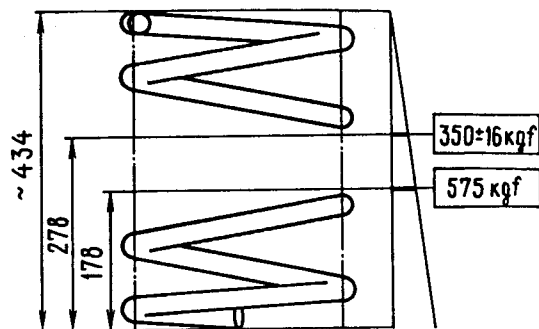

Fig. 4-17. Main Data for Checking Rear Suspension Spring

Protect the rubber parts, bushings and protective coatings against contact with solvents in the course of washing.

Springs. Check the resilience of the spring by the reference points (Fig. 4-17) first compressing it until the coils close.

Note. According to their length under a load of 3425 N (350 kgf), the springs are divided into class A (longer than 278 mm) and class B (278 mm or shorter).

The springs of class A are unmarked, while those of class B are marked black on the external side of the coils.

Check the springs for deformation. Replace the spring if its resilience is other than indicated in Fig. 4-17 or its deformation may interfere with its efficient operation.

Examine the supporting rubber gaskets of the springs and replace them by new ones, if necessary

Radius rods. Check the following:

- distortion of the rods; straighten them, if possible;

- look for cracks on the brackets of the rear axle beam and car body; repair the brackets, if they are cracked;

- examine the flexible bushings of the radius rod joints; replace them by new ones, if necessary using the set of tools 67.7820.9517.

Take the performance curves in accordance with the stand operating instructions after at least five working cycles at a fluid temperature of $(20 \pm 5) ^\circ\text{C}$, a flywheel speed of 60 min^{-1} and a rod travel of 80 mm for the front shock absorber and 100 mm for the rear one.

The curve on the diagram (Fig. 4-19) should be smooth; at the transition points between the

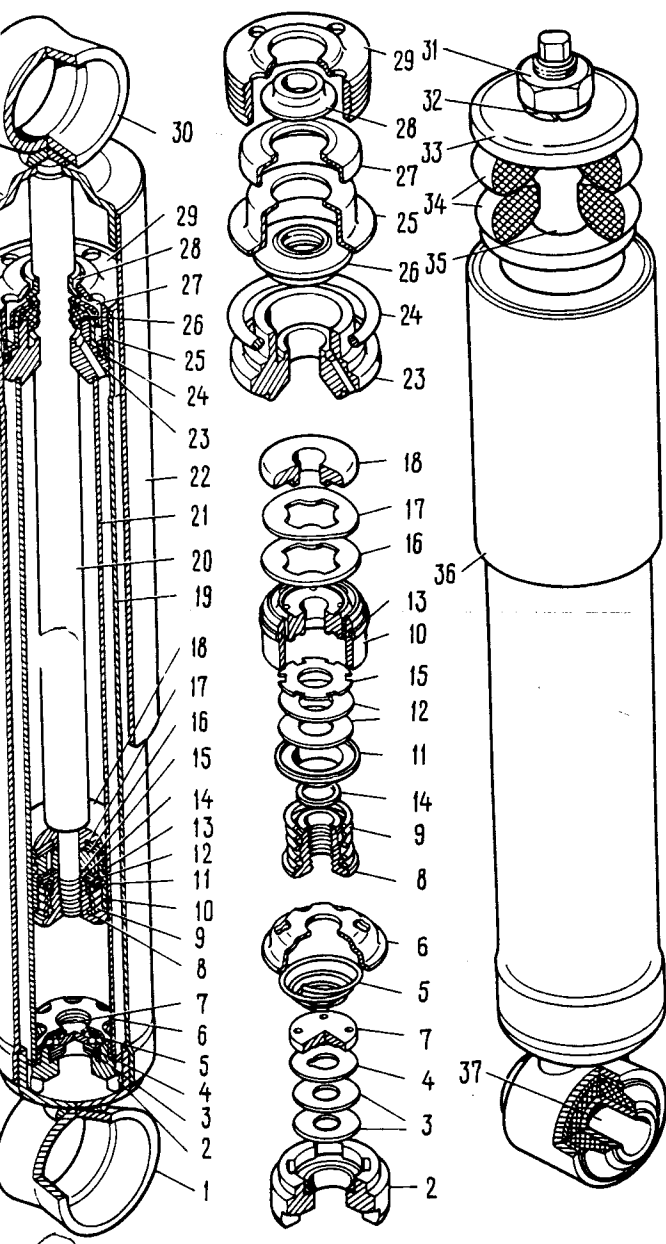

Fig. 4-18. Front and Rear Suspension Shock Absorbers:

- 1 - lower lug; 2 - compression valve body;
 3 - compression valve discs; 4 - compression valve throttling disc; 5 - compression valve spring;
 6 - compression valve holder; 7 - compression valve plate; 8 - rebound valve nut; 9 - rebound valve spring; 10 - shock absorber piston;
 11 - rebound valve plate; 12 - rebound valve discs; 13 - piston ring; 14 - rebound valve nut washer; 15 - rebound valve throttling disc;
 16 - bypass valve plate; 17 - bypass valve spring; 18 - limiting plate; 19 - reservoir;
 20 - rod; 21 - cylinder; 22 - dust shield; 23 - rod guide bushing; 24 - reservoir sealing ring;
 25 - gland holder; 26 - rod gland; 27 - rod protective ring gasket; 28 - rod protective ring;
 29 - reservoir nut; 30 - shock absorber upper lug;
 31 - front suspension shock absorber upper fastening nut; 32 - spring washer; 33 - shock absorber



Fig. 4-19. Shock Absorber Performance Curve:
 I - rebound stroke force; II - compression stroke force

rebound and compression strokes there should be no sections parallel to the zero line.

Evaluation of performance curves. The resistance during the rebound and compression strokes is determined by the maximum ordinates of the corresponding curves.

The peak of the rebound stroke curve on a scale of 47 N (4.8 kgf) per 1 mm should lie at the following distances (A) from the zero line: 25 - 32 mm for the front shock absorbers and 23.5 - 30.5 mm for the rear ones.

The peak of the compression stroke curve on the same scale should lie at the following distances (B) from the zero line: 3.5 - 6.5 mm for the front shock absorbers and 4.5 - 7.5 mm for the rear ones.

The reference values of the ordinates on the curves for the front and rear shock absorbers are given for cold shock absorbers at a fluid temperature of $(20 \pm 5) ^\circ\text{C}$.

After the check remove the shock absorber from the stand and, if necessary, recondition or replace the faulty parts.

Repeat the check to make sure that the shock absorbers function as they should.

DISASSEMBLY AND ASSEMBLY

Wash the shock absorber on the outside and clamp it in a vice.

Note. For clamping the shock absorber and its parts in a vice use special soft jaws 67.7824.9513-001.

Pull the shock absorber rod all the way out, unscrew reservoir nut 29 (Fig. 4-18) with wrench A.57034/R, take operating cylinder 21 with rod 20 and its parts out of the reservoir. Withdraw the reservoir from the vice and drain the fluid.

Using wrench 67.7824.9513-005 remove rod guide bushing 23 from the operating cylinder. Remove piston 10 with the rod from the cylinder and drain the fluid. Drive compression valve body 2 with associated parts gently from the cylinder with a special mandrel.

pad washer; 34 - pad; 35 - spacer bushing;
 36 - shock absorber dust shield; 37 - silent block

Clamp the rod with the piston in a vice with special jaws and unscrew rebound valve nut 8. Remove piston 10 with bypass and rebound valves, guide bushing 23, rod gland 26, gland holder 25 and other parts.

Note. To facilitate inspection of the front suspension shock absorber rod which is covered by the dust shield, it is good practice to press off the dust shield too.

Disassemble the compression valve. For this purpose remove holder 6, then take valve spring 5, plate 7 and discs 3 and 4 one after another out of body 2.

To assemble the shock absorber reverse the disassembly procedure observing the following requirements:

- having assembled the compression valve make sure there is free travel of plate 7 and valve discs;
- press-fit holder 6 on body 2 with a special mandrel;
- press-fit the compression valve into the cylinder with mandrel 67.7824.9513-004;
- to facilitate assembly of the rod-mounted parts use guide 67.7824.9513-003;
- throttling disc 15 of the front shock absorber has two slots on the outside diameter, while that of the rear shock absorber, three slots;

- tighten the rebound valve nut with a torque of 9.8 - 14.7 N.m (1 - 1.5 kgf.m);
- tighten the reservoir nut with wrench 67.7824.9513-002 with a torque of 68.6 - 88.2 N.m (7 - 9 kgf.m).

INSPECTION OF PARTS

Wash all metal parts with gasoline or kerosene and leave them to dry; wash rubber parts with lukewarm water and wipe them with clean cloth.

Check thoroughly to see that the parts meet the following requirements:

- the discs of the compression and rebound valves and the plate of the bypass valve should not be distorted; the plate of the bypass valve should be flat, true to 0.05 mm;
- the working surfaces of the piston, piston ring, rod guide bushing, cylinder and valve parts should be free of scores and nicks that may affect adversely the normal functioning of the shock absorber;
- the springs of the rebound and compression valves should be intact and sufficiently resilient;
- the compression valve discs should be intact and not seriously worn;
- it is good practice to replace the gland by a new one during repairs.

Replace all defective parts and proceed with assembling the shock absorber.